

# PREVENTION OF PREMATURE COLLAPSE A GUIDE TO THE DESIGN, INSTALLATION AND INSPECTION OF CABLE MANAGEMENT SYSTEMS



Version 1.1

May 2021

# ABOUT BEAMA

BEAMA is the long established and respected trade association for the electrotechnical sector. The association has a strong track record in the development and implementation of standards to promote safety and product performance for the benefit of manufacturers and their customers.

Details of other BEAMA Guides can be found on the BEAMA website  
[www.beama.org.uk](http://www.beama.org.uk)

## Acknowledgements

BEAMA would like to thank London Fire, the IET, Hampshire & Isle of Wight Fire & Rescue Service and the Hampshire Constabulary for their support and permission to use their published information.

## DISCLAIMER

This publication is subject to the copyright of BEAMA Ltd. While the information herein has been compiled in good faith, no warranty is given or should be implied for its use and BEAMA hereby disclaims any liability that may arise from its use to the fullest extent permitted under applicable law.

© BEAMA Ltd 2021

Copyright and all other intellectual property rights in this document are the property of BEAMA Ltd. Any party wishing to copy, reproduce or transmit this document or the information contained within it in any form, whether paper, electronic or otherwise should contact BEAMA Ltd to seek permission to do so.

# COMPANIES INVOLVED IN THE PREPARATION OF THIS GUIDE



## ABB Ltd

Tower Court, Courtaulds Way  
Foleshill Enterprise Park  
Coventry, West Midlands CV6 5NX  
Tel: +44 (0) 2476 368 500  
<https://new.abb.com/uk>



## Atkore International

Delta Point, West Bromwich B70 9PL  
Tel: 0121 580 6300  
[www.atkore.com](http://www.atkore.com)



## Cableflow International Ltd

Windsor House, Abbey Barn Road,  
High Wycombe, Bucks HP11 1NN  
Tel: 01494 52 88 11  
[www.cableflow.com](http://www.cableflow.com)



## CMD Ltd

Sycamore Road, Eastwood Trading Estate,  
Rotherham S65 1EN  
Tel: 01709 829511  
[www.cmd-ltd.com](http://www.cmd-ltd.com)



## CMP Products Ltd

Nelson Way, Cramlington NE23 1WH  
Tel: 0191 265 7411  
[www.cmp-products.com](http://www.cmp-products.com)



Holding Power

## Ellis Patents Ltd

High St, Rillington, Malton YO17 8LA  
Tel: 01944 758395  
[www.ellispatents.co.uk](http://www.ellispatents.co.uk)



## Gripple Ltd

Savile St E, Sheffield S4 7UQ  
Tel: 0114 275 2255  
[www.gripple.com](http://www.gripple.com)



## Honeywell Building Technologies

The Arnold Centre, Paycocke Road, Basildon SS14 3EA  
Tel: 01268 563 000  
[www.mkelectric.com](http://www.mkelectric.com)



## Legrand Electric

Great King Street North, Birmingham B19 2LF  
Tel: +44 (0) 370 608 9020  
Email: [powersales.uk@legrand.co.uk](mailto:powersales.uk@legrand.co.uk)  
[www.legrand.co.uk](http://www.legrand.co.uk)



## Marshall-Tufflex

55-65 Castleham Rd, St Leonards on Sea,  
East Sussex TN38 9NU  
Tel: 01424 856600  
[www.marshall-tufflex.com](http://www.marshall-tufflex.com)



## Philip Grahame International Ltd

Montrose Rd, Dukes Park Industrial Estate,  
Chelmsford CM2 6TE  
Tel: 01245 451717  
[www.philipgrahame.co.uk](http://www.philipgrahame.co.uk)



## Prysmian Group

Chicken Hall Lane, Eastleigh SO50 6YU  
Tel: 0870 513 3143  
[www.prysmiangroup.com/en](http://www.prysmiangroup.com/en)



## Schneider Electric Ltd

Stafford Park 5, Telford, Shropshire TF3 3BL  
Tel: +44 (0) 1952 290029  
Fax: +44 (0) 1952 292238  
[www.schneider-electric.co.uk](http://www.schneider-electric.co.uk)



## Unitrunk Ltd

Blaris Industrial Estate, Altona Road,  
Lisburn, BT27 5QB  
Tel: 02892 625100  
[www.unitrunk.co.uk](http://www.unitrunk.co.uk)



## Zip-Clip Ltd

Offas Dyke Business Park,  
Welshpool, Powys SY21 8SS  
Tel: 01686 623366  
[www.zip-clip.com](http://www.zip-clip.com)

# CONTENTS

1	Introduction	05
2	Scope	05
3	Exclusions from Scope	05
4	Definitions & Abbreviations	06
5	Wiring System Zones	07
6	Spacing	09
7	Installation Requirements	09
8	Conclusion	13
9	Bibliography	13
10	Appendices	14



# PREMATURE COLLAPSE BEAMA CABLE MANAGEMENT TECHNICAL COMMITTEE (CMTC)

## 1. Introduction

Following the Grenfell Tower tragedy and the subsequent Hackitt Report the UK Government in December 2018 issued a publication entitled 'Building A Safer Future – An Implementation Plan, whilst also approaching the electrical industry for its support to implement the recommendations contained within the report. BEAMA responded by stating that its members are committed to work with Government to achieve the recommendations and in respect of cable management systems to investigate measures that could be taken to improve the performance of cable management systems to improve fire safety.

Some work had been carried out by the IET prior to the Grenfell tragedy following another fire in a high-rise building. A fire had taken place in Shirley Towers which is a 15-storey concrete tower block of 150 apartments located in the Shirley area of Southampton. In the process of fighting the fire and attempting to clear the building two firefighters died. As an evacuation was attempted escaping firefighters became tangled in fallen cables, both inside and outside the compartment after the heat from the fire had melted the plastic trunking, they were contained in.

Following the Coroner's inquest, recommendations were made to the Government to improve wiring regulations to ensure fire resistant cable support. The IET then amended the 17th Edition Wiring Regulations (BS 7671)

regulations with the publication of Amendment 3, clause 512.11.201. This requirement was subsequently further clarified in the 18th Edition of BS 7671 (521.10.202) stating that *"wiring systems shall be supported such that they will not be liable to premature collapse in the event of a fire."*

Unfortunately, the term premature collapse was not defined and rather than offer clarity to installers this may have added confusion. Furthermore, the fact that there are currently no fire rating tests for the performance of cable management systems within the harmonised product standards, installers have a problem when their clients specify fire safety performance levels for installations.

BEAMA members who represent many of the leading UK cable management manufacturers have been working on further guidance in this area. In conjunction with many stakeholders, including the fire services, the following guidance has been established for installers.

BEAMA members are working on test methods which will be able to rate cable management systems to prevent premature collapse. However, these tests will take time and are yet to be concluded. In the meantime, this document aims to offer guidance to installers to mitigate the level of risk to Fire and Rescue personnel on installation practises. A further document will be published when the testing methods are concluded.

See appendices B and C.

Appendix B: Show examples of poor installations that could lead to disaster.

Appendix C: Shows images from the Shirley Towers report

## 2. Scope

The purpose of this Guidance document is to aid installers to select and erect Wiring Systems to prevent cables from premature collapse due to the effects of heat caused by fire.

The purpose of the document is to verify compliance with current 18th Edition IET Wiring Regulations (BS 7671:2018) regulation 521.10.202. This guidance is to be used for all Wiring Systems (as per BS 7671 110.1.2), which includes fixed wiring for information and communication technology, signalling, cables above false ceilings, control cables and similar systems.

## 3. Exclusions from Scope

- 3.1 Type and performance of cable and conductors
- 3.2 Cables buried in walls and floors
- 3.3 Make-up and performance of substrate
- 3.4 Reaction to fire and smoke emissions
- 3.5 Fire propagation and spread of fire between compartments
- 3.6 BS EN 61534 series Powertrack
- 3.7 Underfloor cable management installations
- 3.8 BS EN 61439-6 Busbar
- 3.9 Construction fixing devices as defined in section 4



## 4. Definitions and Abbreviations

### 4.1 Cable Management System (CMS):

Assembly including different system components intended for the accommodation of insulated conductors, cables and possibly other electrical equipment in electrical and/or communication systems.

*Note: Examples of cable management systems are cable tray systems, mesh cable tray systems, cable ladder systems, cable trunking systems, conduit systems, cable ducting systems, cable cleats, cable ties.*

### 4.2 Collapse:

- (of a structure) suddenly fall down or give way.
- cause (something) to fall down or give way.
- fail suddenly and completely.
- an instance of a structure falling down or giving way.

### 4.3 Construction Fixing Device (CFD):

A component used to secure the CMS or a component of the CMS to the building structure.

### 4.4 Escape Route:

Path to follow for access to a safe area in the event of an emergency.

### 4.5 Fire-resisting:

The ability of a component or construction of a building to satisfy for a stated period of time, some or all of the appropriate criteria specified in the relevant standard test. (Building Reg Document B).

### 4.6 Horizontal Movement:

Occurs when wiring moves outside the specified horizontal axis (see figure 2).

### 4.7 Load (volume):

A maximum allowable volume of cables within a CMS.

### 4.8 Load (mass):

A maximum allowable mass of cables within a CMS.

### 4.9 Looping of Wiring Systems:

This is a common practice used during the installation of cabling, particularly above false ceilings. Single or groups of cables are often 'looped' to provide slack within the installation. (see appendix D).

### 4.10 Non-metallic:

Consisting of non-metallic material only.

### 4.11 Premature:

Occurring or done before the usual or proper time; too early.

### 4.12 Protected Escape route:

Protected escape route. A route enclosed with specified fire-resisting construction designated for escape to a place of safety in the event of an emergency (see also Escape route).

### 4.13 Reaction to Fire:

Response of a CMS in contributing by its own decomposition to a fire, to which it is exposed, under specified conditions.

### 4.14 Suspension:

The threaded rod, wire rope, channel or other bracketry system installed from the CFD to the cable management system.

### 4.15 Vertical Movement:

Occurs when wiring moves outside the specified vertical axis (See figure 1).

### 4.16 Wiring System:

An assembly made up of cable or busbars and parts which secure and, if necessary, enclose the cable or busbars. (BS 7671:2018).

### 4.17 Wiring System Bundles:

Bundling / grouping of more than one cable together (See appendix E).

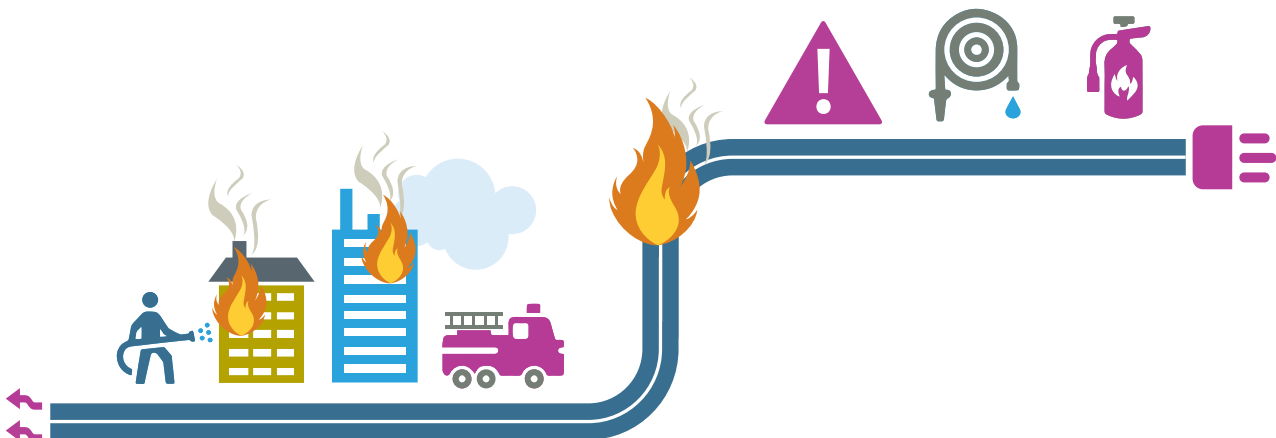

## 5. Wiring System Zones

5.1 In the following table the Zones are numbered to enable specifiers, designers, and installers to understand where the requirements are to be applied, see table 1 and figures 1, 2 & 3:

Table 1

Zone Ref	A	B	C
Height (mm)	$\geq 800 \leq 2100$	$> 2100$	$< 800$

Figure 1

Approved Document K provides recommendations for the minimum height of windows (800mm) above floor level and guarding for windows where they fall below these levels.

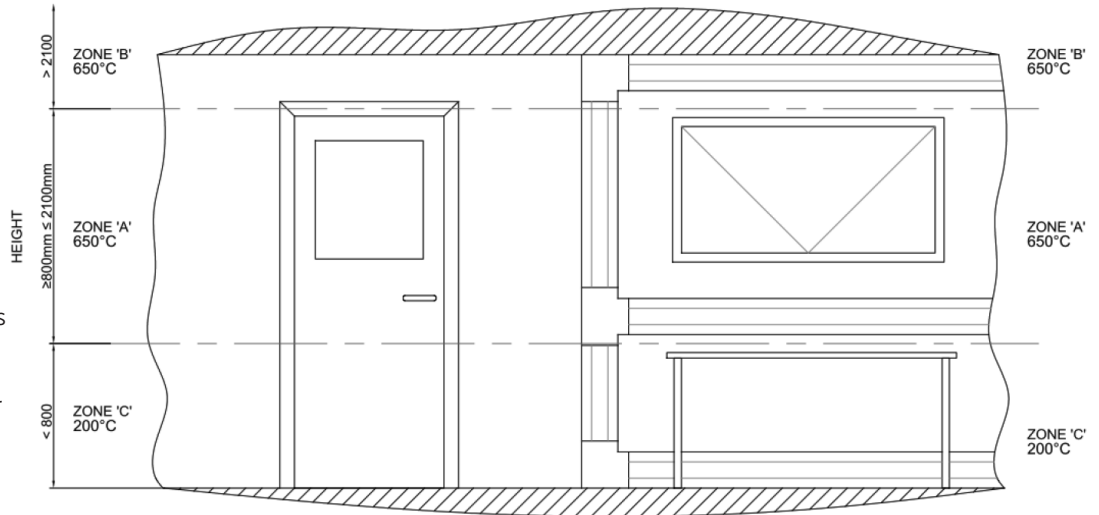

### 5.2 Horizontal Runs:

For horizontal runs in zones 'A' and 'C' the vertical movement as a result of fire, of the wiring system or its contents shall not be greater than **300mm** (See figure 1 and 3).

### 5.3 Vertical Runs:

For vertical runs in zones 'A' and 'C' the horizontal movement, as a result of fire, of the wiring system or its contents shall not be greater than 150 mm (See figure 2).

Note: adequate provision shall be made to allow the continued opening of a non-standard door. (See figure 4).



**IMPORTANT:** For installations in zone 'B' any movement of the wiring system or its contents should not result in any part of the installation entering zone 'A'. (See figure 1, 2 and 3)

Note: The Wiring system in this context does not include lids, covers and sundry parts.

Figure 2

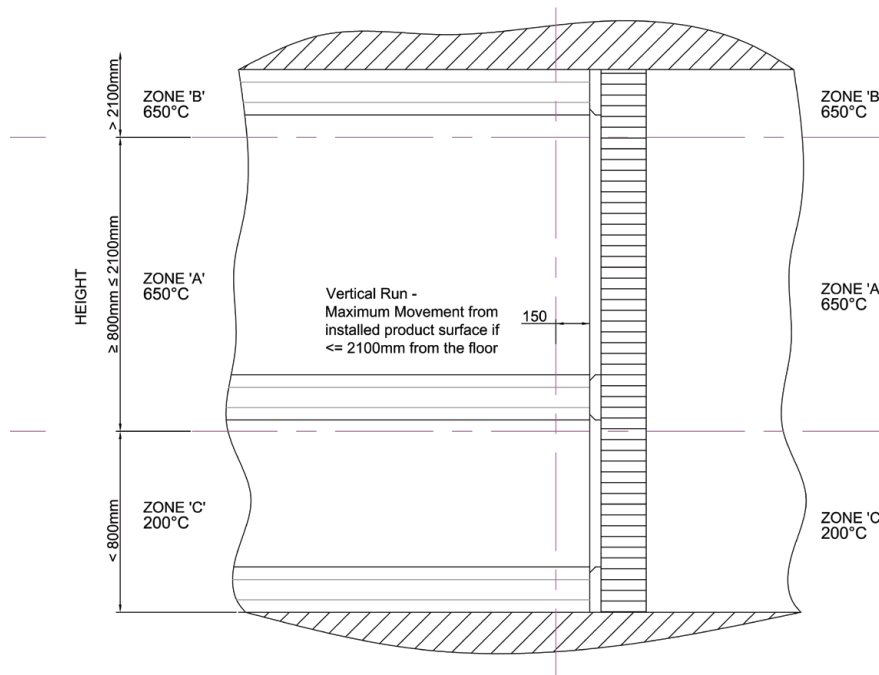
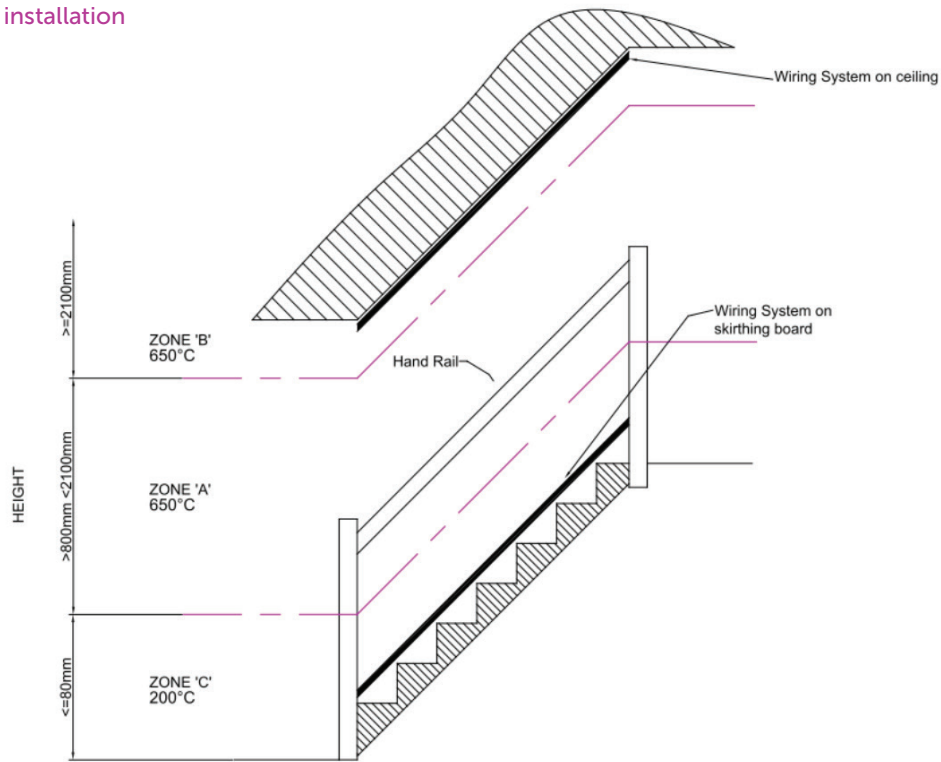

Figure 3: Stair well installation



**5.4 Exclusion Zone:**

To prevent any movement of the Wiring System from obstructing a doorway in the event of a fire no Wiring System parts shall be installed within 150 mm either side of a door opening or less than 300 mm above a door opening, see figure 5.

Where this is not possible, a risk assessment can be made and alternate materials such as metal conduit or enclosed

trunking could be used. No movement of the Wiring system or its content is allowed.

*Exception:* Wiring required for door connected services (i.e., alarms, sensors etc.) which must pass through the exclusion zone must be kept to a minimum and take the shortest path through the zone.

Figure 4: Solid hatch area denotes the exclusion zone

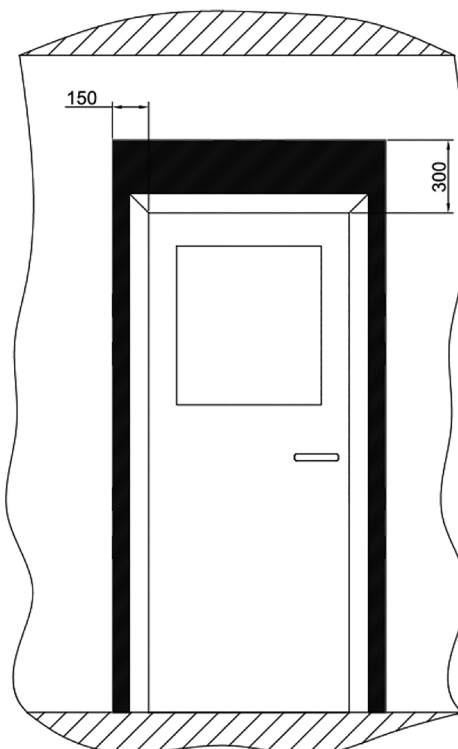



## 6. Spacing

### 6.1 Spacing of cable cleats, clips and or ties:

Must be in accordance with IET 'On Site Guide' Appendix D, Table 2. Supplementary or replacement heat resistant cable cleats, clips and or ties shall be used to achieve conformance with regulation 521.10.202 and section 5 of this guidance document.

**Table 2: Spacings of supports for cables in accessible positions**

Overall diameter of cable, d* (mm)	Maximum spacing of clips (mm)				Mineral insulated copper sheathed or aluminium sheathed cables	
	Non-armoured thermosetting of thermoplastic (PVC) sheathed cables		Armoured cables			
	Generally		Horizontal †	Vertical †	Horizontal †	Vertical †
	Horizontal †	Vertical †				
1	2	3	4	5	6	7
$d \leq 9$	250	400	-	-	600	800
$9 < d \leq 15$	300	400	350	450	900	1200
$15 < d \leq 20$	350	450	400	550	1500	2000
$20 < d \leq 40$	400	550	450	600	-	-

#### Notes:

For the spacing of supports for cables having an overall diameter exceeding 40mm, the manufacturer's recommendations should be observed.

- For flat cables taken as the dimension of the major axis.

† The spacings stated for horizontal runs may be applied also to runs at an angle of more than 30° from the vertical. For runs at an angle of 30° or less from the vertical spacings are applicable.

### 6.2 Trunking and conduit systems:

That have a melt temperature below 650°C shall have supplementary heat resistant cable cleats, clips and or ties spaced in accordance with 6.1.

*Note: The design and materials from which the clip is manufactured may vary between manufacturers and may influence the required number and spacing of clips needed to support the Wiring System, always consult the installation instructions provided by the manufacturer.*

## 7. Installation Requirements

### 7.1 Physical Load:

Cable Management systems are often overflowing and over filled with cables. The maximum allowable load placed on / within the component parts of tray and basket (BS EN 61537) is to be declared in the manufacturer's instructions. For cable capacities for trunking and conduit (BS EN 50085 and BS EN 61386) the following tables from the IET On-Site Guide Appendix E should be referenced (See figures 7 – 11), or seek advice from the manufacturer.

**Table 3: Cable factors for use in conduit in short straight runs**

Type of conductor	Conductor cross-sectional area (mm <sup>2</sup> )	Cable factor
<b>Solid</b>	1	22
	1.5	27
	2.5	39
<b>Stranded</b>	1.5	31
	2.5	43
	4	58
	6	88
	10	146
	16	202
	25	385

**Table 4: Conduit factors for use in short straight runs**

Conduit diameter (mm)	Conduit factor
16	290
20	460
25	800
32	1400
38	1900
50	3500
63	5600

**Table 5: Cable factors for use in conduit in long straight runs over 3m, or runs of any length incorporating bends**

Type of conductor	Conductor cross-sectional area (mm <sup>2</sup> )	Cable factor
<b>Solid or Stranded</b>	1	16
	1.5	22
	2.5	30
	4	43
	6	58
	10	105
	16	145
	25	217

The inner radius of a conduit bend should be not less than 2.5 times the outside diameter of the conduit.

**Table 6: Conduit factors for runs incorporating bends and long straight runs**

Length of run (m)	Conduit diameter (mm)																			
	16	20	25	32	16	20	25	32	16	20	25	32	16	20	25	32	16	20	25	32
	Straight				One bend				Two bends								Four bends			
1	Covered by Tables 3 and 4				188	303	543	947	177	286	514	900	158	256	463	818	130	213	388	692
1.5					182	294	528	923	167	270	487	857	143	233	422	750	111	182	333	600
2					177	286	514	900	158	256	463	818	130	213	388	692	97	159	292	529
2.5					171	278	500	878	150	244	442	783	120	196	358	643	86	141	260	474
3					167	270	487	857	143	233	422	750	111	182	333	600				
3.5	179	290	521	911	162	263	475	837	136	222	404	720	103	169	311	563				
4	177	286	514	900	158	256	463	818	130	213	388	692	97	159	292	529				
4.5	174	282	507	889	154	250	452	800	125	204	373	667	91	149	275	500				
5	171	278	500	878	150	244	442	783	120	196	358	643	86	141	260	474				
6	167	270	487	857	143	233	422	750	111	182	333	600								
7	162	263	475	837	136	222	404	720	103	169	311	563								
8	158	256	463	818	130	213	388	692	97	159	292	529								
9	154	250	452	800	125	204	373	667	91	149	275	500								
10	150	244	442	783	120	196	358	643	86	141	260	474								

**Additional factors:**

- For 38mm diameter use 1.4 x (32 mm factor)
- For 50mm diameter use 2.6 x (32 mm factor)
- For 63mm diameter use 4.2 x (32 mm factor)

**Table 7: Cable factors for trunking**

Type of conductor	Conductor cross-sectional area (mm <sup>2</sup> )	PVC BS 6004 Cable factor	Thermosetting BS 721 I Cable factor
<b>Solid</b>	1.5	8.0	8.6
	2.5	11.9	11.9
<b>Stranded</b>	1.5	8.6	9.6
	2.5	12.6	13.9
	4	16.6	18.1
	6	21.2	22.9
	10	35.3	36.3
	16	47.8	50.3
	25	73.9	75.4

**Notes:**

- (a) These factors are for metal trunking and may be optimistic for plastic trunking, where the cross-sectional area available may be significantly reduced from the nominal by the thickness of the wall material.
- (b) The provision of spare space is advisable: however any circuits added at a later date must take into account grouping, Regulation 523.5.

**Table 8: Factors for trunking**

Dimensions of trunking (mm x mm)	Factor	Dimensions of trunking (mm x mm)	Factor
50 x 38	767	200 x 100	8572
50 x 50	1037	200 x 150	13001
75 x 25	738	200 x 200	17429
75 x 38	1146	225 x 38	3474
75 x 50	1555	225 x 50	4671
75 x 75	2371	225 x 75	7167
100 x 25	993	225 x 100	9662
100 x 38	1542	225 x 150	14652
100 x 50	2091	225 x 200	19643
100 x 75	3189	225 x 225	22138
100 x 100	4252	300 x 38	4648
150 x 38	2999	300 x 50	6251
150 x 50	3091	300 x 75	9590
150 x 75	4743	300 x 100	12929
150 x 100	6394	300 x 150	19607
150 x 150	9697	300 x 200	26285
200 x 38	3082	300 x 225	29624
200 x 50	4145	300 x 300	39428
200 x 75	6359		

**Note:** Space factor is 45% with trunking thickness taken into account.

### 7.2 Looping of Wiring Systems:

To be secured as per this guidance document.

### 7.3 Wiring System Bundles:

To be secured as per this guidance document.

### 7.4 Containment of cables:

Cabling shall be installed inside the cabling area of the CMS (unless designed otherwise) and be secured as per this guidance document. For example: cables shall not be tied directly to the outside of the CMS (See Appendix F).

### 7.5 Additional cable installations:

Shall not be cable tied directly to cables in a pre-existing installation as the sole means of support.

### 7.6 Plastic cable ties:

Are a very popular method of securing bundles of cables to cable tray and other fixings. It should be noted that these are very high-risk items and the use be limited especially in Zone A and B.

### 7.7 Construction fixing devices:

Shall be selected under the advice from the manufacturer to ensure that under the conditions of this document, Wiring Systems shall not be subject premature collapse.

### 7.8 Suspension products:

Should be selected under the advice from the suspension manufacturer, and the installer must ensure that the suspension and its connection to the CFD and the CMS is secure and robust enough so that it shall not cause the wiring system to prematurely collapse.

### 7.9 Maximum limits of cable spillage:

To aid understanding of the horizontal and vertical limitations set out in sections 5 and 6 additional drawings are shown in Appendix A.



## 8. Conclusion

The intention of this guidance is to assist designers and installers in meeting the requirements of 521.10.202 regarding premature collapse. The guidance has been developed by BEAMA experts across the Cable Management sector and the London Fire Brigade. The team will continue this work to include the development of test methods and specifications for Cable Management products with the objective of improving installation safety.

## 9. Bibliography

- 9.1 BS 7671:**  
2018 Requirements for Electrical Installations. IET Wiring Regulations.
- 9.2 BS EN 50085 Series:**  
Cable trunking systems and cable ducting systems for electrical installations.
- 9.3 BS EN 61386 Series:**  
Conduit systems for cable management.
- 9.4 BS EN 61537:**  
Cable management. Cable tray systems and cable ladder systems.
- 9.5 BS EN 61914:**  
Cable cleats for electrical installations.
- 9.6 IEC 61084-1:**  
Cable trunking systems and cable ducting systems for electrical installations. General requirements.
- 9.7 BS EN 62275:**  
Cable Management Systems. Cable ties for electrical installations.
- 9.8 BS EN 12385-1:**  
The manufacture and testing of steel wire rope systems.
- 9.9 BS 8539:2012:**  
The code of practice for the selection and installation of post installed anchors in concrete and masonry.
- 9.9 Approved Document B (fire safety) volume 1:**  
Dwellings
- 9.10 Approved Document B (fire safety) volume 2:**  
Buildings other than dwellings.
- 9.11 Hackitt Report:**  
<https://www.gov.uk/government/publications/independent-review-of-building-regulations-and-fire-safety-final-report>
- 9.12 Shirley Towers:**  
<https://www.hantsfire.gov.uk/about-us/what-we-do/shirley-towers/>
- 9.13 BRE Test report:**  
<https://www.bre.co.uk/page.jsp?id=3652>

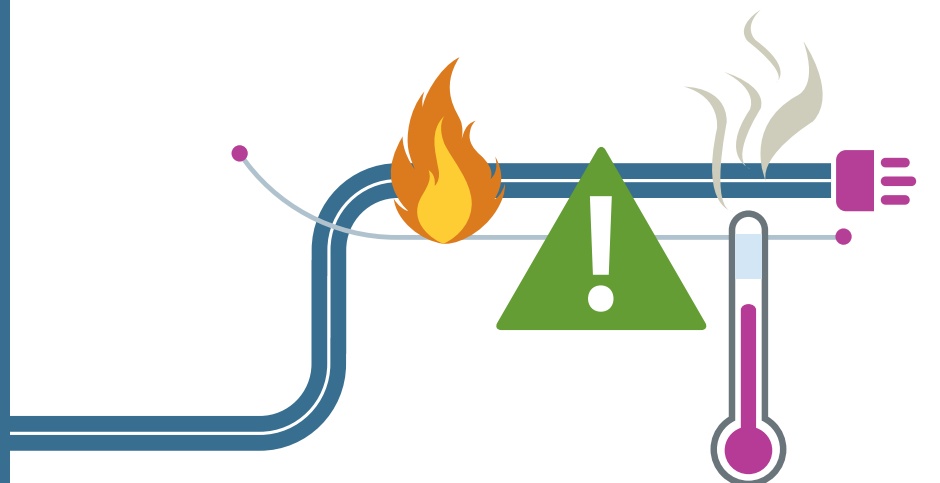

## 10. Appendices

### Appendix A

The dimensions shown are the maximum limits of cable spillage or CMS movement due to increased temperature in the event of a fire.

The following diagrams show various Cable management systems and guidance on their installation in accordance with the preceding document:

Figure 10: Tray, Ladder and Basket Examples

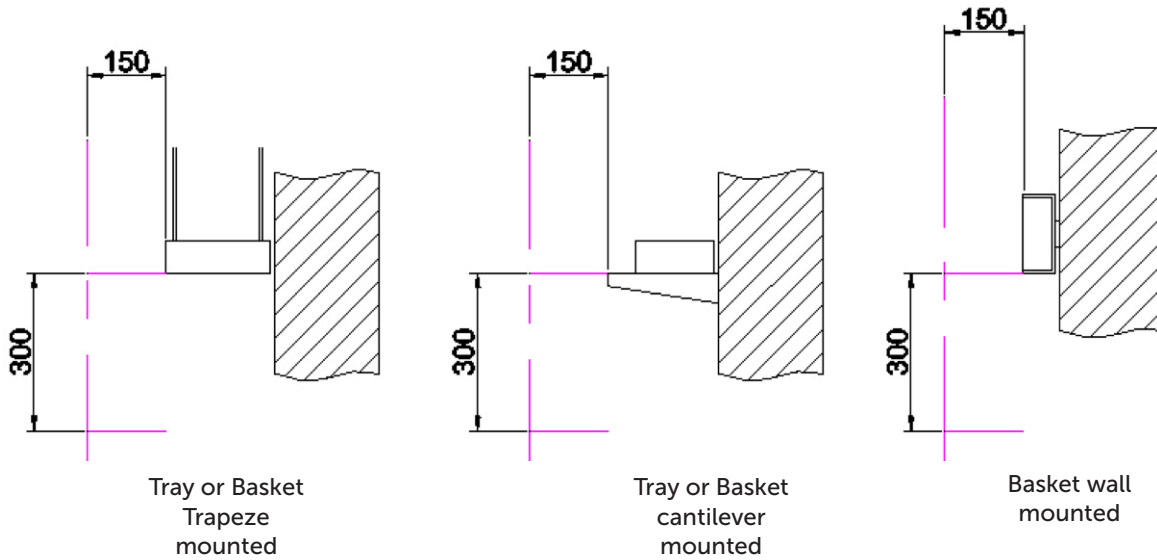

Figure 11: Trunking and Conduit – Horizontal runs on vertical face

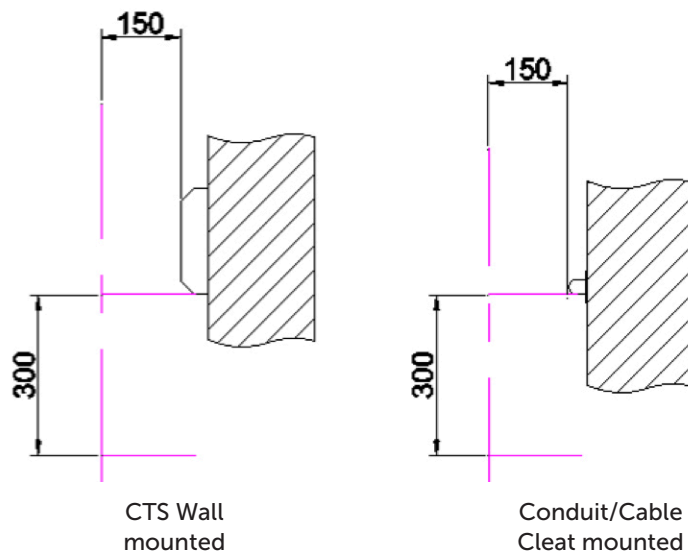

Figure 12: Trunking and Conduit – Internal Bends

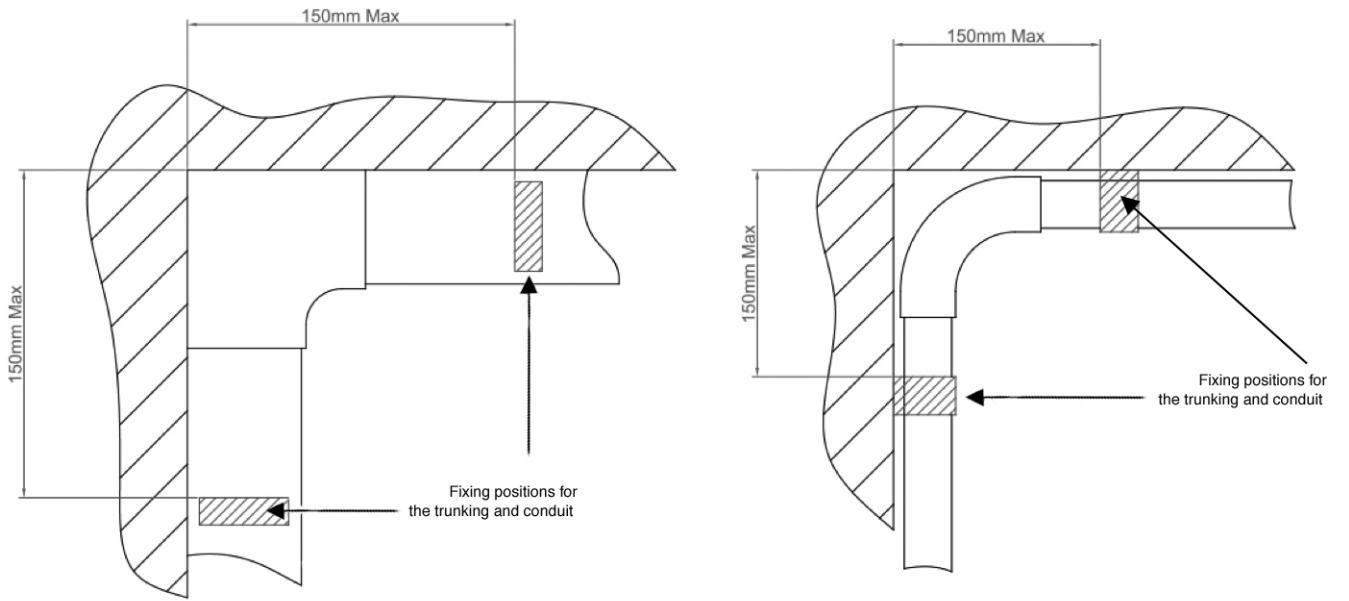
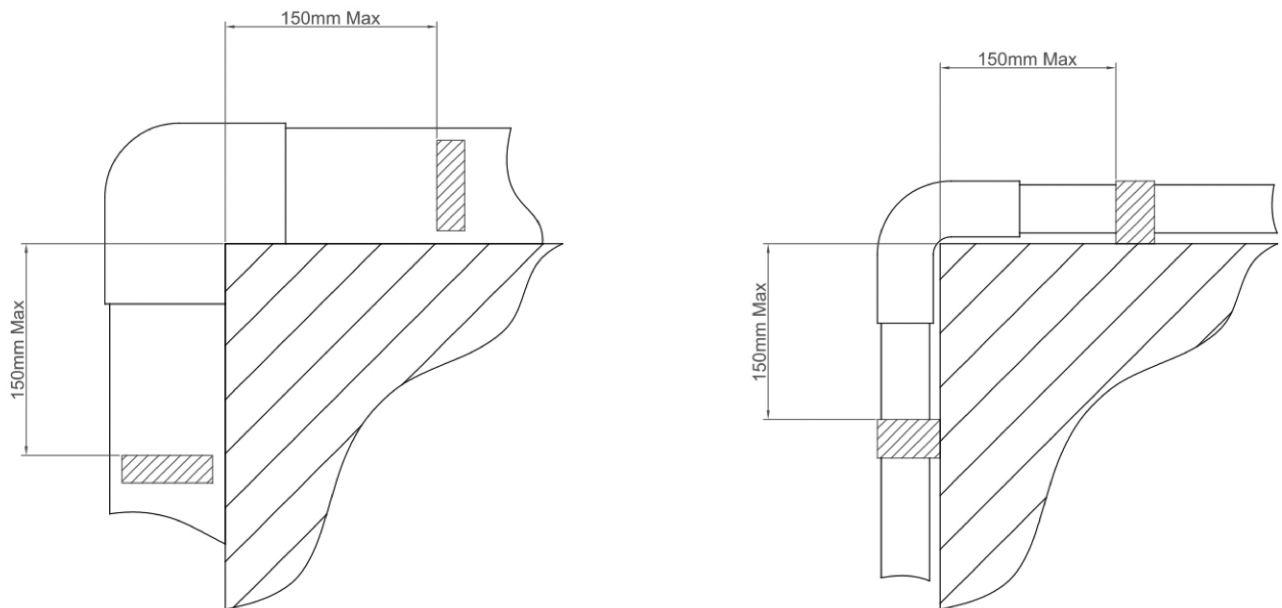

Figure 13: Trunking and Conduit – External Bends



## Appendix B

The following are images showing poor installation practice:





## Appendix C

The following are images from the Shirley Towers report:

Source: Hampshire Constabulary



Post incident photograph showing conditions on the eleventh floor after the escape door from Flat 27 was left open, Note the displaced cables.



Source: Hampshire Constabulary

Post incident photograph of the eleventh floor landing showing displaced cables.

## Appendix D

Example of 'looping':



## Appendix E

Example of 'bundling/grouping':



## Appendix F

Loading of Wiring systems:

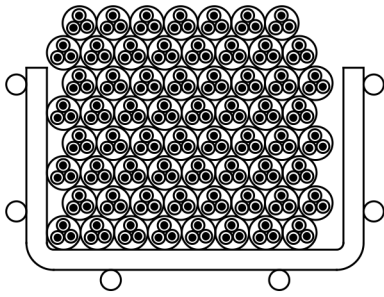

**Appendix F: Figure 1**

An example of over filled cable management.

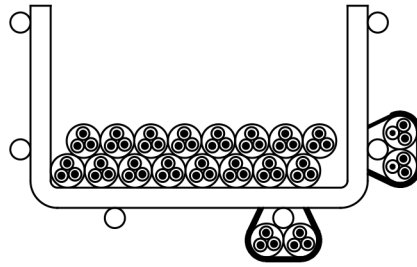

**Appendix F: Figure 2**

An example of cable ties or similar being used to support additional wiring.

NOT ACCEPTABLE

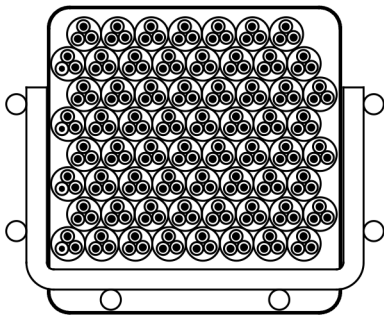

**Appendix F: Figure 3**

Stainless steel banding used to contain wiring system within and to the CMS.

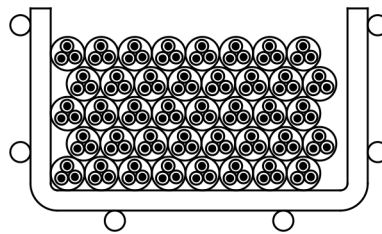

**Appendix F: Figure 4**

No external cables to the CMS and filled below the top edge.

ACCEPTABLE

